

Harrow and District Caledonian Society Dance Class – Wednesday 6th June 2018

**We suggest that dancers follow their own warm-up routine before joining in the dancing.
Information sheets outlining warm-up guidance are available at the class or on the website**

*Our classes comprise a range of difficulty of dances from more straightforward to more complex/challenging.
Dances in darker font are less complex and suitable for all class members – please ensure all our newer members can participate*

(Any dances shown in fainter type are more challenging dances for the more experienced class members)

More experienced dancers should ensure that less experienced dancers get a chance to dance during the dances printed in darker font

SYD

HIGHLAND RAMBLER, THE (R8x40) 3C (4C set) www.youtube.com/watch?v=k1E7QSmCxHQ Roy Goldring Leeds Silver Jubilee

- 1- 8 1s dance in & cast to 2nd place, dance RH across with 3s
 9-16 2s+1s dance LH across, 1L followed by partner cast up round 2L & dance down middle to 1L between 3s & 1M between 2s
 17-24 1s+2s+3s dance down the middle & back
 25-32 1M followed by partner cast down round 2L to 2nd places on own side & turn RH
 33-40 2s+1s+3s circle 6H round & back

SYD

POSTIE'S JIG (J4x32) 4C set <http://vimeo.com/89897897> Roy Clowes Ormskirk Scottish Dances book 5

- 1- 8 1s & 4s set & cast in 1 place, 1s dance ½ Figs of 8 round new end couples
 9-12 1M+4M & 1L+4L cross (men making an arch) & turn corners with free hand to face up/down
 13-16 1s+4s dance down/up (couple dancing up make the arch) & turn corners
 17-24 Repeat bars 9-16 from new positions
 25-32 1s+4s dance ½ R&L, turn partner RH

SYD

MELL SQUARE (S2x32) 4C Sq Set www.youtube.com/watch?v=-qaXS84yvNM Gillian Jennings Platinum Dance Book (Birmingham) 2017

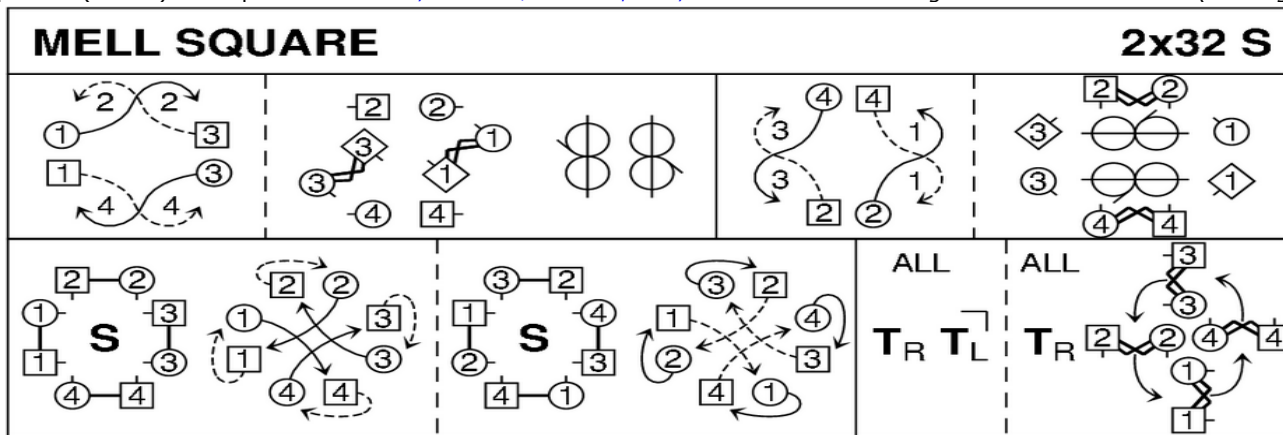

SYD

STAIRCASE IN STYRIA (R5x40) 5C set www.youtube.com/watch?v=bzS8pTX6h9g Margaret Gray The Sunday Class Book 2

- 1- 8 1s+2M **also** 3s+4M dance RH across, 1s+2L **also** 3s+4L dance LH across
 9-16 1s+4M **also** 3s+5M dance RH across, 1s+4L **also** 3s+5L dance LH across
 & 1L **also** 3L end facing out Ladies side with partners behind them
 17-24 1s & 3s dance out Ladies' side & cast up 1 place, cross to Mens side & cast up to original place Ladies looping round by the right
 25-32 1s cross & cast 1 place, 1s followed by 3s dance up & cast (1s to 3rd place, 3s to 2nd place)
 33-40 1s cross & cast 1 place, 1s followed by 5s dance up & cast (1s to 5th place, 5s to 4th place). 2 3 4 5 1
 NB – No stepping up or down until bar 27

I N T E R V A L

SYD

CAPITAL JIG, A (J8x32) 4C set www.youtube.com/watch?v=i8hhJZQ95Ko&t=1 Tine E Mackay 5 dances 2009

- 1- 8 1s+2s **Set+Rotate** (end 1s facing up, 2s down)
 Set, rotate singly & dance on 1 place clockwise, change places RH on sides & dance on 1 place to own sides (1s in 2nd pl)
 9-16 1s dance reels of 3 on own sides (RSh to 2s)
 17-24 1s set & turn RH to face own sides, 1s dance LH across (1L with 2s, 1M with 3s) to end 2nd place opposite sides
 25-32 1s set & turn RH to face opposite sides, 1s dance LH across (1M with 2s, 1L with 3s) ending 2nd place own sides

SYD

BELLE OF BON ACCORD, THE (S4x32) 4C set <http://my.strathspey.org/dd/dancevideo/904/> John Drewry Deeside Book 2

- 1- 8 1L & 3L cross down 1 place & cast up on opp side into centre **as** 1M & 3M dance across & cast down into centre,
 1s+2s & 3s+4s dance RH across
 9-16 1s & 3s dance reel of 4 up & down centre of dance
 17-24 1s & 3s ¾ turn RH to face up **while** 2s & 4s dance up on sides & turn in to face down & all set,
 all circle 4H round to left & end on sides
 25-32 1s & 3s lead up between 2s/4s crossing over & cast down 1 place,
 1s & 3s turn 2H & 1s lead down to 4th place **as** 3s cast up on own sides to 2nd place

SYD

CAPE BRETON ISLAND (R4x32) 4C set 3S & 4s on opp sides John Drewry, Summer Collection 88

- 1- 8 1s+2s **also** 3s+4s Set & Rotate : -
 Set, rotate singly & dance on 1 place clockwise, change places RH on sides & dance on 1 place to own sides (1s in 2nd pl)
 9-16 1s & 4s dance out ends, cast back to 2nd/3rd places,
 1M+4L & 1L+4M in prom hold dance round (Men LSh to LSh) ¾ to face up/down
 17-24 1M+4L dance LSh reel of 3 across with 2s & 1L+4M with 3s to end 2 4 (1)(3)
 25-32 All circle 8H round & back

SYD

HUNTING HORN, THE (J8x32) 3C (4C set) www.youtube.com/watch?v=mF8QBdIpWiE Peter McBryde SCD Archives

- 1- 8 1s cast 1 place, cross RH, cast below 3s & dance up middle to 2nd place BtoB in centre for Double Triangles
 9-16 1s dance Double Triangles & end facing 2nd corners
 17-24 1s dance diagonal reels of 4 with 2nd corners, pass partner LSh to face 1st corners
 25-32 1s dance reels of 4 with 1st corners, pass partner LSh to end in 2nd place facing out to start next sequence